

## Packaging and Handling Supplier and Interplant Requirements

### Table of Contents

<b>1.0 Introduction</b> .....	2
1.1 Summary of Changes ..	2
1.2 Abstract .....	3
1.3 Objective & Purpose .....	3
1.4 Application .....	3
<b>2.0 General Packaging Requirements</b> .....	4
2.1 Consistency .....	4
2.2 Environmental Packaging .....	4
2.3 Additional Information .....	7
<b>3.0 Shipping Environmental Hazards</b> .....	8
3.1 Shock .....	8
3.2 Vibration .....	8
3.3 Compression .....	8
3.4 Temperature .....	8
3.5 Moisture .....	8
3.6 Electrostatic Discharge .....	9
3.7 Package Testing .....	10
<b>4.0 Containers (Primary Packaging)</b> .....	11
4.1 Minimum Corrugated Board Strength .....	12
4.2 Edge Crush Test (ECT) vs. Mullen Equivalents .....	12
4.3 Carton Closure Methods .....	14
<b>5.0 Palletization</b> .....	15
5.1 Pallet Requirements .....	16
5.2 Unit Load Shippers (ULS) .....	21
5.3 Heavy Package Requirements .....	21
5.4 Reusable Containers .....	21
5.5 Security Shipments .....	22
<b>6.0 Marking and Labeling</b> .....	26
6.1 Labeling Requirements .....	26
6.1.1 Individual Package Marking .....	26
6.1.2 Shipping Packages : Celestica Outer Packaging Bar Code Label Standard .....	26
<b>7.0 Distribution Shipment Criteria for Defects</b> .....	27

## 1.0 Introduction

### 1.1 Summary of Changes (**version 18**)

The following are some of the changes

#### *1.1.1 Additions:*

- 3.5 Dimethyl Fumerate ban in desiccants as per 2009/251/EC – EU regulations
- 5.0 Edge Protector Recommendations
- 5.3 Heavy labels / symbols addition to identify packages

#### *1.1.2 Revisions:*

- 2.3 URL link update
- 6.1 URL link update
- 6.1.2 URL link update

#### *1.1.3 Deletions:*

- 2.2.2 Examples of heavy metals item classification
- 5.1 Use of Methyl Bromide for Pallet treatment

## 1.2 Abstract

This specification defines the **minimum general** requirements for the preparation, packaging, labeling, marking and palletization required for parts, subassemblies, products and materials shipped to any Celestica facility. All previous versions are obsolete and should be discarded.

## 1.3 Objective & Purpose

This document is not intended to supersede specific packaging instruction for individual products. Any deviations to this specification shall be described in the specific contract or purchase order.

These requirements help ensure that items shipped to Celestica are received in satisfactory condition, thereby reducing the overall costs due to damage in transit and minimize in-house handling activities.

This document may be referred to as CELQ-001-STD-39 or PK0763-1.

## 1.4 Application

It is the supplier's responsibility to ensure their packaging methods and materials comply with all applicable laws and regulations. This is especially true for materials classified as hazardous or dangerous.

It is the supplier's responsibility to ensure shipments are economically packaged palletized and to ensure shipments provide for safe delivery of the products, providing adequate protection against damage and deterioration during shipment, handling and storage to the final destination.

Compliance to the Celestica packaging requirements, safety guidelines, and legal regulations contained in this specification will be enforced as a condition of purchase per Celestica purchase contracts.

Non-compliance results in extra costs being incurred at the receiving site and at any time, Celestica reserves the right to:

- Reject and return any shipments received that are improperly packaged or identified.

- Charge the supplier for the cost of labor and materials for any repackaging resulting from non-compliance with this or any other specification referenced on the Purchase Order.

- Remove from its list of approved vendor sources any supplier that, after notice, repeatedly fails to comply with its packaging requirements.

Any shipper requiring deviation from requirements contained in this specification, PK0763-1, must receive authorization from the Celestica Packaging Engineering prior to shipment.

Packing slips of approved non-conforming shipments must be noted with the name of the authorizing Celestica Purchasing Agent and the date of authorization.

The intent of this document is to reduce total operating costs for Celestica, extended throughout the supply chain. In situations where these requirements generate onerous inefficiencies in the supplier's process, please bring this to our attention via the Purchasing representative or the Site Operations representative for timely considerations.

## 2.0 General Packaging Requirements

The general requirements listed in this section must be met for all shipments and purchases. Unless additional requirements are identified in this or other Celestica packaging specifications, all other packaging decisions are left to the supplier's discretion. (Note: Packaging costs must be included in all part quotations provided to Celestica Purchasing / Commodity Management)

Products will be prepared for shipment in accordance with the best economical commercial practices shipments will be packed to withstand the normal hazards of transportation, air freight, multiple handling, storage, and at times, ocean freight and exposure.

The package must provide enough protection to ensure its contents arrive **damage free**. Any of the following Industry Specifications or an equivalent may be used as a guide to qualify the packaging material.

- American Society for Testing & Materials - ASTM D-3951 – Standard Practice for Commercial Packaging
- IATA Dangerous Goods Regulations
- International Maritime Dangerous Goods Code (IMDG)
- Uniform Freight Classification Rule 41 Mullen Burst Test
- American Society for Testing & Materials--ASTM D-4169 - Performance Testing of Shipping Containers and Systems
- American Society for Testing & Materials--ASTM D-642 - Method for Determining Compressive Resistance of Shipping Containers, components and Unit Loads.
- International Safe Transit Association--ISTA Pre-Shipment Test Procedures
- National Motor Freight Traffic Association - NMFC Item 222 and Item 180
- United States Code of Federal Regulations (CFR)
- EIA – 541 Packaging Material Standards for ESD Sensitive items.
- ANSI/ESD S20:20 Protection of Electrical and Electronic Parts, Assemblies and Equipment.
- (EU) RoHS Directive
- EU Directive on Packaging and Packaging Waste(94/62/EC)
- Export Requirements for Solid Wood Packaging Materials (SWPM) – ISPM15
- Standard for Handling, Packing, Shipping and use of Moisture/Reflow sensitive surface mount devices – IPC/JEDEC (J-STD-033)
- Classification of Non-IC Electronic Components for Assembly Processes – IPC/J-STD-075

## 2.1 Consistency

Parts must be packaged consistently, both in terms of the containers used and quantity of parts per container for a given part number. If the total delivered quantity is not evenly divisible, the remaining parts shall be packaged, identified with quantity, and marked "partial." Suppliers must get the approval of Celestica Purchasing prior to initiating a change to the container size or quantity.

## 2.2 Environmental Packaging

Celestica is very concerned about the effect packaging waste has on the environment. When choosing materials to package items to be purchased by Celestica, shippers must consider the impact on the environment of discarded packing materials. Where possible, all packaging materials used should be made of recyclable materials and contain the highest recycled material content consistent with its type and functional requirements. Reusable packaging should be considered where applicable.

Celestica's strategy for solid waste management system can best be achieved by acting upon the focus items identified below.

## 2.2.1 Ozone Depleting Chemicals

Celestica has adopted the following requirements:

Halogenated chlorofluorocarbons (CFCs) and hydrogenated chlorofluorocarbons (HCFCs) must not be used to manufacture materials used to package parts or products being shipped to Celestica.

Suppliers of all types of expanded packaging material and chemical components used for the processing of expanded packaging material (i.e. foam-in-place urethane components) must ensure material have not been manufactured with or contain chlorofluorocarbons (CFCs) or hydrogenated chlorofluorocarbons (HCFCs).

Other alternatives to CFC and HCFC blowing agents include: - Hydrocarbons (e.g. Pentane and Water or Steam)

Steps should be taken to minimize the use of Methyl Bromide (commonly used as a fumigant for solid wood packing materials) through the use of alternative treatment methods or materials where applicable.

Certification by the supplier may be required for packaging materials that are purchased by Celestica.

## 2.2.2 Heavy Metals

Celestica has adopted the following requirements:

No packaging material or packaging component shall contain any amount of lead, cadmium, mercury or hexavalent chromium as an element which has been intentionally introduced into its composition as a part of its manufacture, forming, distribution, or printing. The sum concentration level of incidental amounts of lead, cadmium, mercury or hexavalent chromium present in any packaging material or component shall not exceed 100 parts per million (100 ppm) by weight (0.01%) of that material or component.

Sometimes toxic substances may be formed or released by reactions of packaging materials when exposed to certain conditions. As the discarded package is subjected to treatment in the disposal system (incinerated in resource recovery facilities or buried in landfills), toxic components may be released into the air or onto land and potentially into groundwater. Although packaging is not the major contributor of these toxic agents in the solid waste stream, removal of these toxic substances from packaging can make solid waste management safer.

Certification by the supplier may be required for any packaging material purchased by Celestica for resale of products, parts and supplies to Celestica customers.

## 2.2.3 Controlled Environment-Related Substances used in Packaging Manufacture.

With regard to the environment related controlled substances contained in packaging components, this section clarifies banned substances, substances to be phased out and substances to be reduced in order to comply with related laws, prevent its use for Celestica related products and to reduce the influence of these substances upon the Eco-system.

The List of such substances are as follows: -

Substances	
Chlorinated Organic Compounds	Polychlorinated biphenyls (PCB) - flame retardant contained in plastics.
	Polychlorinated naphthalenes (PCN)
	Chlorinated paraffins (CP)
	Mirex (Perchlordecone) - flame retardant contained in paper.
	Other chlorinated organic compounds. (used plasticizers or flame retardant contained in plastics)
Brominated Organic Compounds	Polybrominated biphenyls (PBB) - flame retardant contained in plastics.
	Polybrominated diphenylethers (PBDE) - flame retardant contained in plastics.
	Tetrabromobisphenol-A-bis(2, 3-dibromopropylether) (TBBP-A-bis)
	Other brominated organic compounds. (banned from January 1, 2005). – molding dies that were made before December 2002. Dies made after January 2003 must not contain PBDE.
Organic tin compounds (Tributyl tin compounds, Triphenyl tin compounds)	
Formaldehyde	Wooden products made from chipboard or plywood for worldwide distribution
Polyvinyl chloride (PVC) and PVC blends - (banned from January 1, 2005)	
	Thermoformed clamshells

## 2.2.4 Source Reduction

Celestica encourages the source reduction (minimization) of packaging materials used to package and ship our products, parts and supplies, provided safety and protection are not compromised.

## 2.2.5 Reusable Packaging Systems

Celestica favors reusable package designs over expendable or recyclable ones provided other costs are equivalent.

The design of a reusable container system is a joint effort between Celestica and its supplier. The involvement of each is necessary to fully understand the logistics affecting operations at either location.

Where a returnable packaging solution is in place, consideration should be given to a collapsible design for optimization of the return program.

## 2.2.6 Recycling

Suppliers are required to:

Use paper based packaging materials that are easily recycled like corrugated paperboard, molded pulp, etc.

Use water-based inks or inks which are FDA/USDA approved. Use tapes and starch glues that do not inhibit recycling. Design packages so that components can be easily separated prior to recycling.

Do not bond two or more dissimilar materials together (e.g. urethane pad glued to corrugated)

Avoid the use of free-rise foam-in-place materials

Avoid the use of Polyvinyl Chloride (PVC) for packaging applications

Avoid the use of free-flowing dunnage materials (ie loose peanuts).

Note: Depending upon the country of manufacture an appropriate recycling symbol may be used. Multiple symbols are permissible but not recommended.

## 2.3 Additional Information

For additional copies or general inquiries: -

Internet access: [http://www.celestica.com/uploadedFiles/Global\\_Services/PK0763-1\\_Rev18.pdf](http://www.celestica.com/uploadedFiles/Global_Services/PK0763-1_Rev18.pdf)

Or follow the route below;

<http://www.celestica.com>

From the web page above, select "What We Do"

On the pull down menu, select "Overview"

At the bottom of the page, select the "For information on fulfillment, packaging and distribution for suppliers" link.

On the "Supplier Resources" page, select the "Packaging and Handling: Supplier and Interplant Requirements document."

For Technical Assistance, please contact: -

Edward Adalakun  
Celestica  
844 Don Mills Road  
Toronto  
Ontario  
M3C 1V7

Voice: 416 – 443 – 7450 Fax: 416-448-4810

Email: [eadelaku@celestica.com](mailto:eadelaku@celestica.com)

Or for Celestica Toronto Site Operations Assistance, regarding deviations please contact: -

Email: [pkgeng@Celestica.com](mailto:pkgeng@Celestica.com)

### **3.0 Shipping Environment Hazards**

Consideration must be given to all hazards encountered in the distribution environment. The following terms represent hazards which are typically found in the shipping environment.

#### **3.1 Shock**

Intermittent forces caused by dropping the package to the floor, stacks tipping over, bumps in the road, or any number of other causes. Express carrier or small package delivery systems represent the most severe environment for shock.

#### **3.2 Vibration**

Continuous forces which are applied to the package whenever it is physically transported. Airplanes, trucks, and conveyors will impart some level of vibration to the package. Vibration causes abrasion, that can be especially damaging to painted and/or textured external machine covers and cause fatigue in electrical connections.

#### **3.3 Compression**

During shipping, handling, and storage, packages will be subjected to dynamic and static compression due to stacking. Compression strength diminishes considerably in humid/moist environments and when the stacks are not aligned.

Packages or containers must withstand dynamic stack heights of at least 2.5 m (8 feet) since this may be how high they are stacked in trucks and other vehicles. Furthermore, packages or containers stored in a warehouse should be able to withstand static stack heights of 5.0 m (16 feet), measured from floor to top of stack, for a period of 30 days without visible degradation to any package or container or its contents.

#### **3.4 Temperature**

Products may encounter temperature extremes ranging from  $-40^{\circ}\text{C}$  ( $-40^{\circ}\text{F}$ ) to over  $+60^{\circ}\text{C}$  ( $+140^{\circ}\text{F}$ ) in the distribution environment. Packaging materials and methods must be effective at these extremes as well.

#### **3.5 Moisture**

Moisture sensitive items should be packaged in hermetically sealed barrier materials with desiccant. Conversely, if desiccant is not used it is best not to seal the bags.

Sheet metal is best protected with volatile corrosion inhibitors (VCI's) instead of barrier materials.

Avoid the use of packaging materials inside the sealed barrier bag that contain or have the ability to absorb moisture.

See CELQ-033-STD-17, IPC/JEDEC J-STD-033 and J-STD-075 for handling, packing, shipping and use of moisture/reflow components.

Barrier materials used in moisture controlled packaging include:

Requirement	Moisture Barrier Materials
Parts that are slightly moisture sensitive, but are without moisture sensitive ratings	<b>Good:</b> Polyethylene (6 mil) provides a reasonably good moisture barrier for parts which are not extremely moisture sensitive.
	<b>Better:</b> Materials which are made to MIL B-131-F (Military Std). These are foil/polyethylene combinations with various types of outside layers (scrim fabric, polyester, Tyvek™, or Kraft paper). The Water Vapor Transmission Rates (WVTR's) for these materials is 0.02 grams of water/24hours/100 square inches.
	<b>Best:</b> Materials which combine polyethylene with a sputtered foil layer. These minimize pinholes and can achieve WVTRs as low as 0.002 grams of water/24hours/100 square inches. Materials achieving WVTRs this low should only be used for long term storage of highly valuable parts.
Parts that have moisture sensitivity ratings	As per J-STD-020, J-STD-033 & J-STD-075

**Volatile Corrosion Inhibitors (VCI's) :** Bare sheet metal parts such as chassis, brackets or other plated sheet parts must be wrapped in a VCI bag or paper. This will prevent corrosion on the parts

**IMPORTANT: VCI's should not be used for assemblies or parts containing disk drives.**

**Desiccant Use and Handling:** Silica gel or activated clay type desiccants are preferable. Desiccants are packed in multiple units, which define their moisture absorbing capacity, not their volume.

It is generally advisable to use 1 unit of desiccant for every 562cm<sup>2</sup> (90in<sup>2</sup>) of barrier surface area or 0.03m<sup>3</sup> (0.83ft<sup>3</sup>) of volume inside the barrier. This amount can be varied depending on the WVTR of the barrier and the intended storage time.

Desiccants must be carefully handled prior to use, as they may become saturated in a matter of hours if left exposed, even in an air-conditioned room. It must always be sealed inside airtight drums or sealed barrier bags prior to use.

Activated clay type desiccants are reusable. They can be re-activated in an oven by baking at 96C ± 5C for 6 hours. This can restore approximately 90% of its capacity.

Silica gel cannot be re-activated in this manner.

The desiccant quantity is also specified in J-STD-033 if the part has an MSD rating; please follow the specified quantities if you are preparing materials with MSD ratings for shipment.

**Do not use materials that contain Dimethyl Fumerate (DMF) in concentrations greater than 0.1mg/kg. DMF protects items from mould growth, but has been found to be a skin irritant and is now banned in Europe. Please refer to the European Union Commission Decision 2009/251/EC, for compliance.**

**Note:** All ocean shipments require some form of moisture protection.

### 3.6 Electrostatic Discharge (ESD)

ESD is one of the most pervasive hazards for electronic components. Static discharges of as low as 50 volts can destroy or weaken (latent damage) certain classes of electronic components. As a point of reference, people cannot feel a static discharge of less than 3,000 volts. This is why it is critical to consistently handle these parts in a static safe manner and use packaging materials that can protect against these hazards.

### **3.6.1 Celestica's ESD Packaging Strategy**

All electronic components and subassemblies will be treated as ESD Sensitive, regardless of the part's actual level of ESD sensitivity. This will eliminate confusion as to when to apply proper protective techniques.

The best method for packaging ESD sensitive parts is to use a Static Dissipative material closest to the ESD sensitive part. A Conductive material is then used to surround the ESD sensitive item to provide an electrostatic shield.

All packaging materials used for ESD protection should be thoroughly tested and approved prior to their use. It is recommended that the following specification be used to test ESD protective packaging materials.

Electronic Industries Association Standard (EIA) 541 - Packaging Material Standards for ESD Sensitive Items.

### **3.7 Package Testing**

The package must provide enough protection to ensure its contents arrive damage free. Celestica reserves the right to audit a supplier package design for conformance to these standards. Individual Supplier Quality Plans should address package verification / approval methods. Any of the Industry Specifications listed in section 2.0 (General Packaging Requirements) may be used.

## 4.0 Containers (Primary Packaging)

Table 1 - Primary Packaging Do's and Don'ts. This table summarizes the basic requirements for the use of containers. Illustrations and additional explanations follow.		
Item	Do	Do Not
General	Protect parts from: <ul style="list-style-type: none"> <li>Dust, dirt and abrasion</li> <li>All reasonable hazards during shipping handling and storage, such as shock vibration, compression moisture and electrostatic discharge (ESD).</li> <li>Provide Packaging that permits safe handling, shipping and storage.</li> </ul>	<ul style="list-style-type: none"> <li><b>Do not</b> use crates, wirebound boxes or expendable wooden containers unless corrugated containers will not provide adequate protection. If crates are used to ship to Celestica Toronto, please notify Site Ops (see section 2.3)</li> <li><b>Do not</b> use more than 15% by weight or 25% by volume of expanded foam in a container.</li> </ul>
Containers	<ul style="list-style-type: none"> <li>Use boxes of sufficient strength to permit stacking during shipment and storage.</li> </ul>	<ul style="list-style-type: none"> <li><b>Do not</b> use the container's flaps to extend the height of the container.</li> </ul>
Bags	<ul style="list-style-type: none"> <li>When used, bags should be made of 2 mil or greater high density polyethylene material.</li> </ul>	
Closure	<ul style="list-style-type: none"> <li>Use pressure sensitive film tapes (polyester or polypropylene) or reinforced gummed tape for corrugated containers.</li> <li>Use tape which is a minimum of 50 mm or 2 inches wide.</li> <li>Use strapping or reusable wire brackets for wooden crates / containers.</li> <li>Use strapping / banding for half slotted, telescoping or sleeve and cap containers.</li> <li>Use the "H" taping method to reinforce the bottom flaps of heavy containers.</li> </ul>	<ul style="list-style-type: none"> <li>Staples stitched to manufacturer's joints are acceptable since the packages are not to be opened there.</li> </ul> <p>This is primarily a safety concern, not an environmental one.</p>
Labels	<ul style="list-style-type: none"> <li>Use "heavy" symbols on containers that exceed 12kg (26lbs).</li> <li>Use item identification and barcode labels as described in section 6.0.</li> </ul>	<ul style="list-style-type: none"> <li>Labels applied by the carrier <b>must not</b> be placed over top of the content labels applied by the supplier.</li> </ul>
Dunnage	<ul style="list-style-type: none"> <li>Use corrugated inserts and dividers.</li> <li>Select the right size of container for the parts to minimize dunnage.</li> </ul>	<ul style="list-style-type: none"> <li><b>Do not</b> use any form of "free flow or loose fill" dunnage material.</li> <li><b>Do not</b> use news print paper as dunnage.</li> <li><b>Do not</b> stuff wrong sized cartons with excess dunnage.</li> </ul>

## 4.1 Minimum Corrugated Board Strength

The following table provides minimum board strength for cartons of various sizes. Exceptions to these requirements are approved only if tests are conducted which verify that the package design provides equivalent compression strength.

Container Style	Sum of Container Length + Width +Depth			
	0 - 762mm 0 - 30 inches	763 - 1270mm 30.1 - 50 inches	1271 - 2286mm 50.1 - 90 inches	Over 2286 Over 90
Regular Slotted Container (RSC)	1896 kPa 275 psi, SW	1896 kPa 275 psi, DW	2413 kPa 350 psi, DW	2413 kPa 350 psi, DW
Half Slotted Container (HSC)	1896 kPa 275 psi, SW	1896 kPa 275 psi, DW	2413 kPa 350 psi, DW	N/R <sup>1</sup>
HSC Palletized	N/R <sup>1</sup>	N/R <sup>1</sup>	2413 kPa 350 psi, DW	2413 kPa 350 psi, DW
Full Telescoping Style	1896 kPa 275 psi, SW	1896 kPa 275 psi, SW	2413 kPa 350 psi, SW	2413 kPa 350 psi, DW
Sleeve and cap Style	N/R <sup>1</sup>	N/R <sup>1</sup>	2413 kPa 350 psi, DW	2413 kPa 350 psi, DW
Roll End Tuck Top Mailers	1896 kPa 275 psi, SW	2413 kPa 350 psi, SW	2413 kPa 350 psi, SW	N/R <sup>1</sup>
All Other Styles	1896 kPa 275 psi, SW	1896 kPa 275 psi, DW	2413 kPa 350 psi, DW	2413 kPa 350 psi, DW

N/R<sup>1</sup> = Package style not recommended for this size of container.

## 4.2 Edge Crush Test (ECT) vs. Mullen Equivalents

Either method of specifying corrugate can be used for packages of equal size and gross weight. See Table #3 for approximate equivalency values.

Both burst (Mullen) and ECT grades of fiberboard are acceptable for corrugated boxes, however the two grades have different properties that may reflect in their performance during shipment. Burst grade fiberboard is manufactured to attain certain minimum levels of tensile and tear strength, collectively measured by the Mullen burst test. ECT grade fiberboard is manufactured to attain a minimum level of crush resistance that relates to good stacking strength in the finished box and this is measured by the Edgewise Crush Test. Although sufficient stacking strength is an important attribute needed in small parcel systems, durability is even more important as the corrugated box must retain and protect its contents in manual and automated handling. Durability is closely related to tensile and tear properties. To help control the grade of fiberboard, it is encouraged to specify basis weight (minimum combined weight of facings) when procuring corrugated fiberboard boxes.

Single Wall		Double Wall	
ECT (lb./inch)	Mullen (lb./in <sup>2</sup> )	ECT (lb./inch)	Mullen (lb./in <sup>2</sup> )
32	200		
40	250	48	275
44	275	51	350
55	350	61	400
		71	500
		82	600

## 4.2.1 Getting the most out of the Corrugated Cartons and Inserts

1. The flute direction in the outer carton should always run vertically.
2. Specify that corrugated inserts are to be 0.06 - 0.12" (1.5 - 3.0mm) taller than the specified inside depth (height) of the carton. This ensures that the dividers contribute to the overall carton strength.
3. Doublewall materials with lower board strength will usually provide more compression strength than singlewall materials with higher burst values. Doublewall also offers the best overall value relative to its enhanced performance.
4. When using corrugated sleeves inside cartons align the flutes horizontally for the sleeve. The corners will add strength vertically and the horizontal flutes will add strength laterally. This improves overall compression strength. Cartons will be oriented in any direction during most phases of the distribution network.

### 4.3 Carton Closure Methods

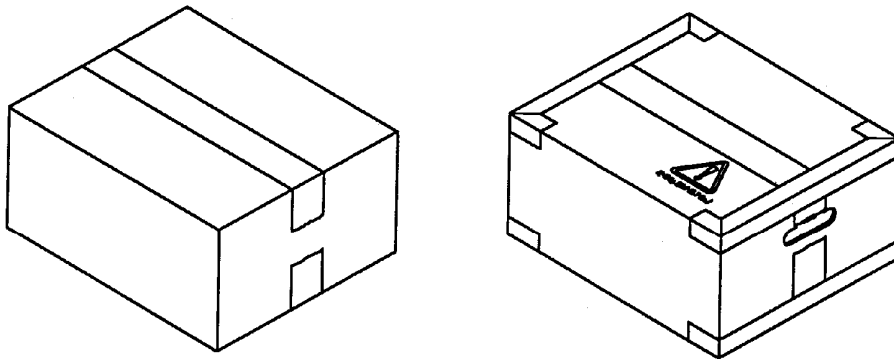

Figure 1. Carton taping methods. Lightweight cartons (left), heavier cartons weighting more than 4.5 kg (10 lbs.) (right).

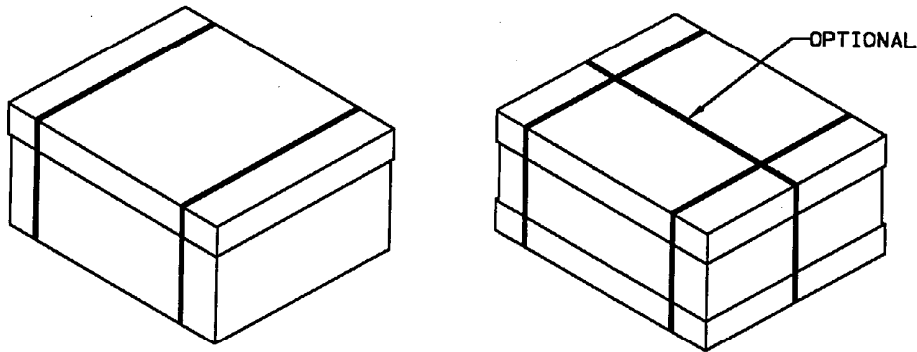

Figure 2. Carton banding methods. Single cover boxes (left) and double cover boxes (right) should be *banded*, not taped. Edge protectors may be omitted when banding automatically and not attaching the carton to a pallet.

## 5.0 Palletization:

<b>Table 4 - Palletization and securement Do's and Don'ts.</b> <b>This table summarizes the basic requirements on palletization. Illustrations and additional explanation follow.</b>		
<b>Item</b>	<b>Do</b>	<b>Do Not!</b>
Pallets	<ul style="list-style-type: none"> <li>Use Celestica Standard (See further notes in section 5.1)</li> </ul>	<ul style="list-style-type: none"> <li><b>Do not</b> use pallets which have bark on them.</li> <li><b>Do not</b> use broken or poorly constructed pallets</li> <li><b>Do not</b> use pallets without bottom deck boards.</li> <li><b>Do not</b> use pallets which have evidence of insect damage on them (such as grub holes).</li> <li><b>Do not</b> use alternate pallet materials without Celestica Approval.</li> </ul>
Packaging	<ul style="list-style-type: none"> <li>Use unit load shippers whenever possible.</li> <li>Cut down the height of the unit load shipper, if the headspace is greater than 3 inches.</li> <li>Use empty cartons marked "empty" to fill void spaces.</li> <li>Use unit load shippers if the pallet contains more than three layers of cartons.</li> <li>Use top caps sized for the load when palletizing cartons.</li> </ul>	<ul style="list-style-type: none"> <li><b>Do not</b> use top caps on top of cartons if the cap is too big or too small</li> <li><b>Do not</b> use free flow dunnage materials to fill voids.</li> <li><b>Do not</b> use printed newspapers to fill voids</li> <li><b>Do not</b> allow containers to overhang the pallet.</li> </ul>
Palletization / Unitization	<ul style="list-style-type: none"> <li>Build only cubic, stackable loads.</li> <li>Occupy at least 80% of the pallet surface.</li> <li>Palletize shipments consisting of a package weighing in excess of 32kg (70lbs)</li> <li>Palletize multiple purchase orders of one part number on a pallet.</li> </ul>	<ul style="list-style-type: none"> <li><b>Do not</b> mix production and non-production materials.</li> <li><b>Do not</b> haystack or pyramid stack cartons on a pallet.</li> <li><b>Do not</b> palletize a shipment consisting of a single package weighing less than 32kg (70lbs)</li> </ul>
Edge Protectors	<ul style="list-style-type: none"> <li>Use full length pressed fiber-board (Angleboard™, V-board™ or similar). . These are effective for horizontal banding patterns or for aligning corners of stacked boxes on pallets (vertically) and for fortifying the stacking strength of cartons.</li> </ul>	<ul style="list-style-type: none"> <li><b>Do not</b> use coated materials (metal or clay coat) for environmental benefits.</li> <li><b>Do not</b> use metal edge protectors – these may present a safety hazard (sharp edges).</li> <li><b>Do not</b> use scrap pieces of corrugated fiberboard.</li> </ul>
Stretch Wrap	<ul style="list-style-type: none"> <li>Use mechanically applied stretch wrap.</li> <li>Start with properly adjusted machine which pre-stretches the film</li> <li>Use 2-way banding before stretch wrapping, if feasible.</li> <li>Tie the stretch wrap to the pallet directly and cover all corners.</li> <li>Use a top cap outside of vertical corner boards under the stretch wrap.</li> <li>Clear stretch wrap with unique markings or shrink-wrap may be used for security purposes.</li> </ul>	<ul style="list-style-type: none"> <li><b>Do not</b> use hand applied stretch wrap unless combined with 4-way banding.</li> <li><b>Note:</b> Do not confuse Shrink-wrap with Stretch wrap. Shrink-wrap is applied with heat to form a tight load while stretch wrap is applied from a roll and is pre-stretched by the applicator.</li> </ul>
Banding/ Strapping	<ul style="list-style-type: none"> <li>Use at least two bands</li> <li>Use polyester banding -- 13mm (0.50") wide and 0.5mm (0.20") thick.</li> <li>Use steel banding for loads over 363kg (800 lbs.), if the banding is being used to hold the load onto the pallet.</li> <li>Use crimp or heat seal banding closures.</li> <li>Use the banding notches (not the fork notch) for cross bands on stringer pallets.</li> <li>Use 2-way banding plus stretch wrap for most shipments.</li> </ul>	<ul style="list-style-type: none"> <li><b>Do not</b> use metallic banding for loads weighing less than 363kg (800 lbs.).</li> <li><b>Do not</b> use "buckle" style hand applied banding fasteners.</li> <li><b>Do not</b> use staple or nails through the bands. Staples may be used to "frame" bands used for permanent reinforcements of crates. However, the staples themselves must not puncture the bands. Whenever such bands are used, also mark these containers with graphical symbols, which says, "Do not cut this band".</li> </ul>

**Notes:**

- When multiple cartons are shipped on a pallet (without a Unit Load shipper), at least one of the labeled sides of each carton must face an exterior edge of the pallet. The carton that contains the packing slip must be located on the top layer of cartons with the packing slip facing an exterior edge of the pallet. (If the packing slip is enclosed within one of the palletized multiple cartons, the carton must be palletized as one of the outside cartons on the pallet and must be located on the top layer. The carton that contains the packing slip must be identified).
- All items shall be secured onto pallets by strapping and /or stretch wrap.

## 5.1 Pallet Requirements

In compliance with the Canadian Waste Diversion Regulation, which shall not promote the burning or land-filling of Packaging waste materials, Celestica-Canada has approved the use of corrugated pallets, for in-bound deliveries, specifications of which should conform with the wooden pallet design below -

At any time, Celestica reserves the right to:

Reject and return any shipments received using the wrong pallet.

Charge the supplier for the cost of labor and materials for any re-palletizing resulting from non-compliance with this or any other specification referenced on the Purchase Order.

Remove from its list of approved vendor sources any supplier that, after notice, repeatedly fails to comply with its pallet requirements.

Any shipper requiring deviation from requirements contained in this specification, PK0763-1, must receive authorization from the Celestica Packaging Engineering prior to shipment.

Where further assistance is required or for questions regarding the use of the above corrugated pallets for in-bound shipments into Celestica-Canada, please contact Celestica Packaging Engineering at: -

[Pkgeng@Celestica.com](mailto:Pkgeng@Celestica.com)

**Wooden Pallets:** used must be constructed according to National Wood Pallet and Container Association specifications. Pallets shall be in good repair (no broken or severely split deck-boards, protruding nails, rotten wood, etc.). Pallets shall be provided with a minimum clear distance of 2.5 inches (64mm) between top and bottom deck-boards, and a minimum clear distance of 28" (711mm) between the side deck-boards, for purposes of handling by pallet jacks. A four-way entry pallet is preferred. Minimum top deck coverage must be 60%.

**Regulatory Compliance:** Where wooden packaging is used, their construction must use wood in compliance with any global regulation. All non-manufactured wooden pallets or packaging must be treated and marked regardless of origin or destination. with the appropriate compliance markings.

- Solid Wood Packaging Material (SWPM) must be treated in accordance with the standards stated in ISPM15. These include, but is not limited to:
  - pallets, pallet collars, skids
  - dunnage
  - crating, packing blocks
  - drums, cases, load boards

**Preferred Method of Treatment**

**Heat Treatment (HT)**

- SWPM must be heated in accordance with a specific time-temperature schedule that achieves a core minimum temperature of 56 degrees Celsius for a minimum of 30 minutes.
- Kiln-drying and chemical pressure impregnation (CPI) may also be considered as long as they meet the heat treatment specifications.

A complete summary of these requirements can be obtained from any of the following webpages: -

[www.inspection.gc.ca/english/plaveg/for/cwpc/wdpkge.shtml](http://www.inspection.gc.ca/english/plaveg/for/cwpc/wdpkge.shtml)

[www.aphis.usda.gov/ppq/swp/](http://www.aphis.usda.gov/ppq/swp/)

<https://www.ippc.int/IPP/En/default.jsp>

**Marking Procedure:** The marking shall consist of the treatment initials (HT), the material classification, the country of manufacture and the supplier designation. Mark the pallet, crate or wooden packaging assembly a minimum of one time on an exterior surface. Duplicate markings on the opposite exterior surface are preferred by International standards and is strongly recommended.

**IPPC Marking Requirement**

- The mark shown below is to certify that Solid Wood PM has been properly treated.

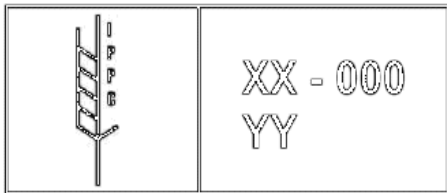

- IPPC - Certification symbol
- XX - 2 letter ISO country code
- 000 - Unique number assigned by National Plant Protection Organization (NPPO)
- YY - Abbreviation of approved treatment (HT)
- The mark should be placed on at least 2 opposite sides of the article being certified.

**Wooden Pallet Sizes:** Maximum in bound pallet size should be:

<u>Design Type</u>	<u>Size.</u>
Stringer design	40 x 48"

**Maximum Palletload Size.** The dimensions of the total shipping container, including pallet, shall be limited to **40"** (1016mm) in long x **48"** (1219mm) wide and **72"** (1829mm) in height; maximum.

Any deviations from the specified maximum dimensions must be approved by Celestica Packaging Engineering or the receiving location prior to shipment.



**Pallet requirements for Celestica Monterrey in Mexico only:-**

Material on pallets that bound for Celestica Monterrey (CMX) should conform to the measurements below:-

Maximum Loaded Pallet Height	48"
Maximum Pallet width	40"
Maximum Pallet Length	48"
Maximum Pallet Load	Same as pallet above.
Specifications	Same as above (the only difference being the orientation of required dimensions)

Pallet shall contain no broken or multiple split deck boards, protruding nails or rotten wood.  
 Pallet shall provide a minimum clearance of 2.5" (64mm) between the top and bottom deck-boards  
 Pallet shall provide a minimum clearance of 17" (432 mm) between the runners for purposes handling by pallet jacks.

Any deviations from the specified maximum pallet dimensions for Celestica Monterrey (CMX) must be approved by CMX warehouse or the Incoming Department, prior to shipment.  
 Contact for the CMX warehouse is Rodolfo Barbosa ext-2737 or email at [rbarbos@celestica.com](mailto:rbarbos@celestica.com)

See diagram below

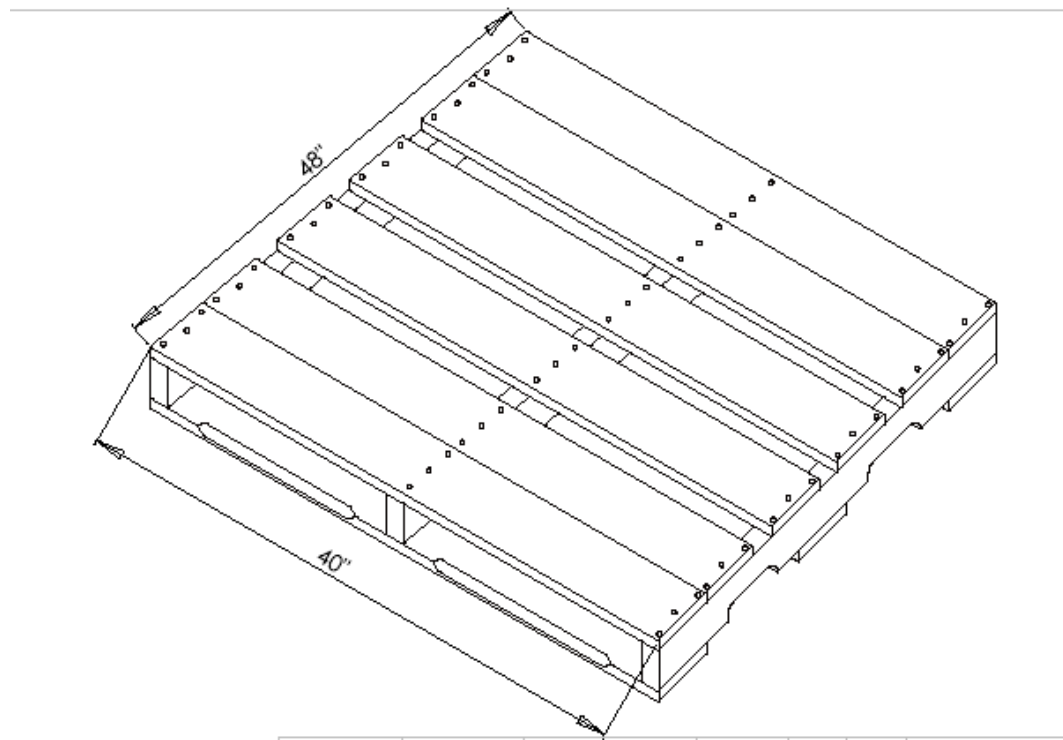

**Stacking**

Packaging shall be designed to withstand a minimum 116" (2945 mm) stack height of similar package footprints and must pass National Motor Freight Rule 180. A "Do Not Stack" label does not absolve the suppliers of their responsibility for proper packaging.

The top surface of the pallet load should be flat to permit stacking for both carrier and warehouse requirements.

### Unitizing

Pallet loads should be unitized to stabilize the load and prevent damage to the cartons during transportation. Unitization can be accomplished using one of the two alternative methods outlined below.

### Banding

Two-way banding using a non-metal banding material should be used as required to help stabilize loads during transit. Angle boards or edge protectors are required under bands to prevent damage to cartons.

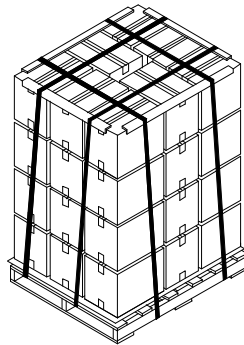

### Stretch Wrap

Shrink films or stretch wrap should adequately secure the load to the pallet. The film must have adequate tack to prevent loose ends from hanging off the load. A minimum of three (3) spiral wraps should be applied per unitized load.

Angle boards must be used on the four vertical corners to prevent the corrugated from collapsing due to stretch wrap pressure. The length of the angle boards should be equal to the height of the load.

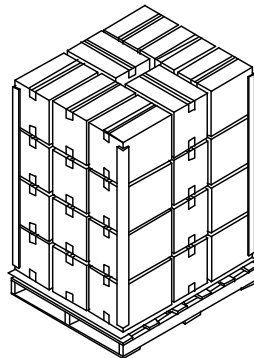

**Note: no pallet overhang is allowed**

## 5.2 Unit Load Shippers (ULS)

Pallet loads should be overpacked when loads are heavy, transported interstate or internationally.

## 5.3 Heavy Package Requirements

Manually handled packages in excess of 12kg (26lbs.) are considered heavy and must carry a cautionary symbol illustrating the proper lifting techniques for handling heavy packages.

Heavy packages should be designed with features to improve safety and convenience when handling. Features include handles, handgrips, or hand holes to facilitate manual handling. These must be reinforced or designed appropriately to ensure no tear during handling.

Hand holes (when used) should be cut with a score at the top line, so that the material is in the hole. This reduces contamination and improves gripping comfort. Interior cushions should be designed to align with the hand hole and interior packaging should not interfere with the hand hole.

Dimensions vary with the size and material of the carton and equipment used to make it. Your carton supplier typically selects standard sizes available.

Preprinted “Heavy” symbols on the carton if possible, using the same colors as the other graphics on the carton. If this is not practical, use labels instead. The use of ink stamps for this application is discouraged.

The actual weight (vs the weight range) may be printed if is exact and unchanging for the package.

## 5.4 Reusable Containers

To ensure compliance with marking regulations, proper classification and to reduce duty payments, all reusable containers must be marked as follows a minimum of one time:

**REUSABLE CONTAINER  
CONTAINER MADE IN XXX**

Where “XXX” is the full country name in English where the reusable container was made.

If the reusable container is not empty, and the reusable container is the primary container (the innermost level of packaging in which an article will be received by the ultimate purchaser), the reusable container must also indicate the country of origin of its contents. For example, a reusable container made in Japan, but filled with goods with a country of origin of China must be marked as follows. The first two lines would be permanent and the last line temporary if the container may be used for other items from other countries;

**REUSABLE CONTAINER  
CONTAINER MADE IN JAPAN  
CONTENTS MADE IN CHINA**

**Important:** Do not use this marking for packaging capable of reuse, but which in fact are not reused.

## 5.5 Security Shipments

Serialized seals are recommended for container closure, pallet strapping, and/or trailer sealing when shipping proprietary materials. Serial numbers must be recorded on the shipping instructions.

Banding should be placed far enough from the edge of the package to prevent anyone from slipping banding over the package edge or corner and replacing it undetected. Opaque stretch wrap or shrink-wrap materials may also be used. Contact the Celestica *Traffic* or *Security Departments* for complete information.

In cases where high dollar value parts shipments are involved, Celestica Purchasing may require the use of additional packaging measures in order to deter in-transit thefts. For individual carton shipments, the carton will be sealed with tamper evident security tape. (E.g. - Product Identification - 3 inch polyester tape with generic security message)

The carton should be taped closed per Figure #1 using the method for sealing cartons weighing more than 4.5 kgs.

For bulk shipments, the interior cartons as well as the unit load shipping carton should be taped closed per Figure #1 using the taping method for sealing cartons weighing more than 4.5 kgs. In addition, the entire load should be stretchwrapped to the pallet.

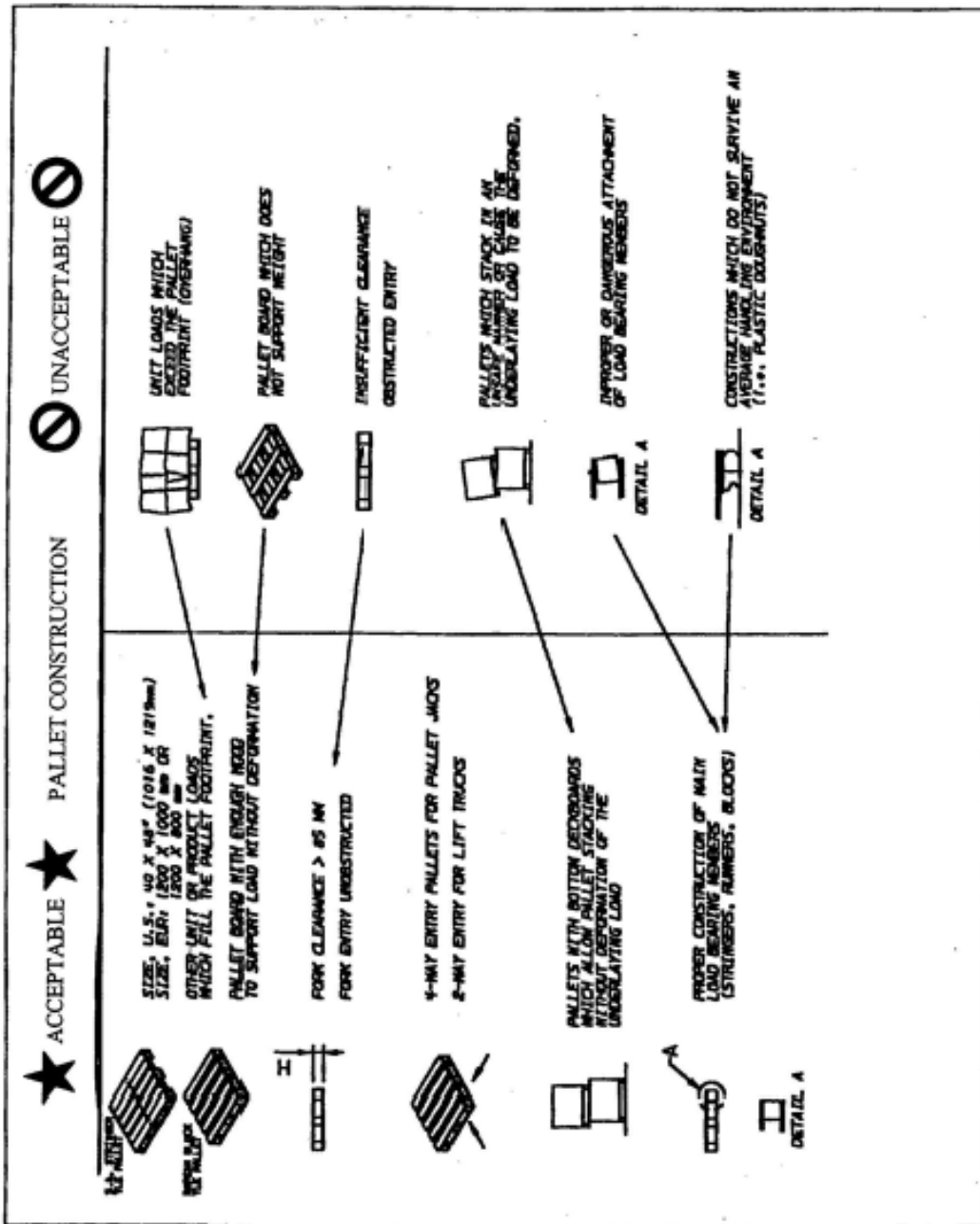

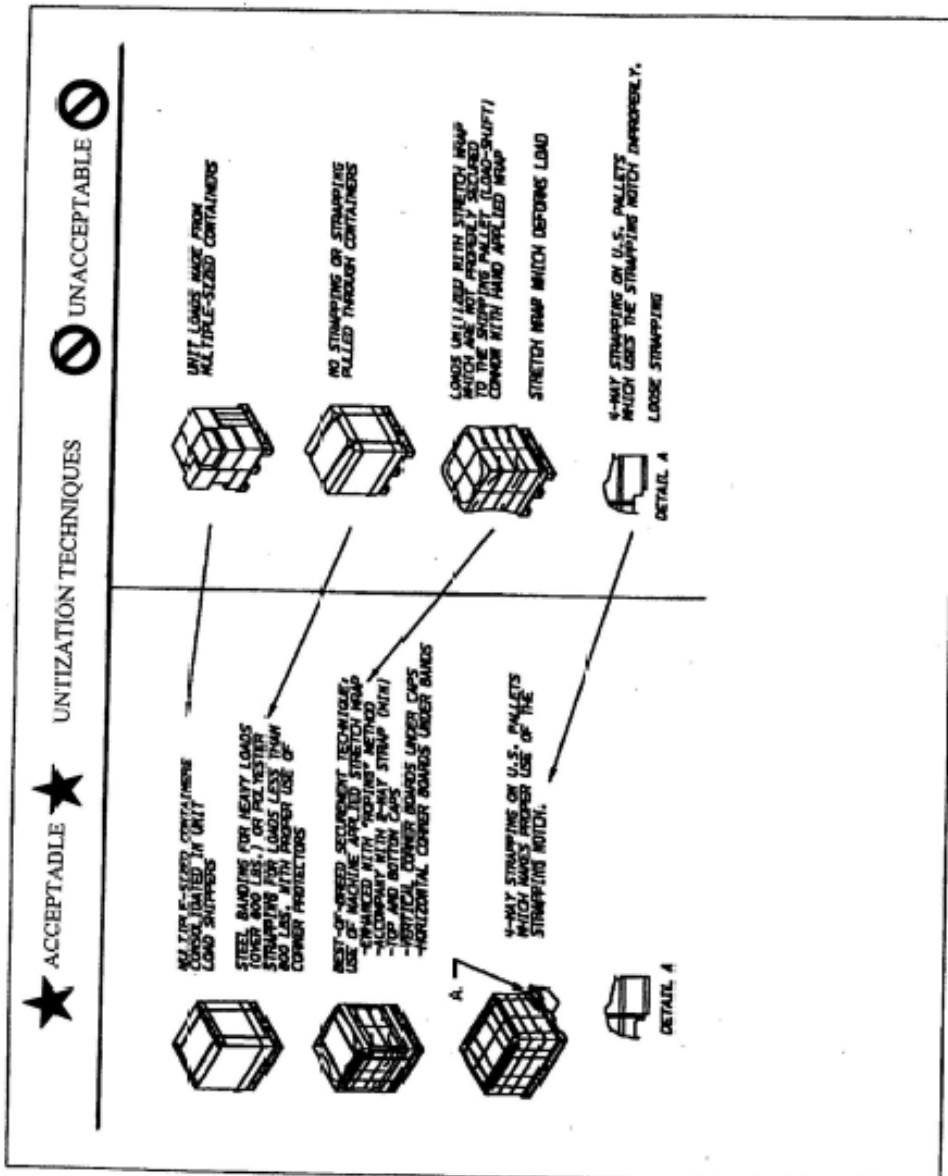



## 6.0 Marking and Labeling:

Table 5. Marking and labeling Do's and Don'ts. This table summarizes the basic requirements on marking and labeling. Illustrations and additional explanations follow later.

Item	DO	Do Not!
Labels	<ul style="list-style-type: none"> <li>Machine generate labels.</li> <li>Make the label information legible, indelible and permanent.</li> <li>Use waterproof ink or clear acetate tape to protect handwritten information if used.</li> <li>Use tags, stamps or pre-printed cartons in place of labels where appropriate.</li> </ul>	<ul style="list-style-type: none"> <li><b>Do not</b> obscure or cover labels with non-clear with tape or banding.</li> <li><b>Do not</b> hand-write information</li> <li><b>Do not</b> leave old labels on re-usable containers.</li> <li><b>Do not</b> use "DO NOT TOP LOAD" or "DO NOT STACK" labels -- they tend to be ignored.</li> <li><b>Do not</b> place other shipping labels over the Celestica material barcode label.</li> </ul>
Cartons/Boxes	<ul style="list-style-type: none"> <li>Mark the carton with the country of origin if required.</li> </ul>	<ul style="list-style-type: none"> <li><b>Do not</b> use labels less than 25mm x 75mm (1" x 3")</li> </ul>
Pallet Loads	<ul style="list-style-type: none"> <li>Mark pallet loads with country of origin if required.</li> <li>Mark pallet load with "mixed" or "multi" if goods from more than one country of origin in packed inside.</li> <li>Staple labels to wooden crates.</li> </ul>	<ul style="list-style-type: none"> <li><b>Do not</b> use labels less than 50mm x 100mm (2" x 4")</li> <li><b>Do not</b> allow staples securing labels to protrude from wooden crate.</li> </ul>

## 6.1 Labeling Requirements

Receiving and storage of materials requires incoming loads to be easily and quickly identified.

(See notes in section 5.0)

Reference CELQ-033-STD-051

[www.celestica.com](http://www.celestica.com)

From the web page above, select "What We Do"

On the pull down menu, select "Overview"

At the bottom of the page, select the "For information on fulfillment, packaging and distribution for suppliers" link.

On the "Supplier Resources" page, select the "Bar Coding Standard for Procured Production Goods (CELQ-033-STD-051)" document.

### 6.1.1 Individual Package Marking

Several countries require that each imported item have the country of origin marked on the item itself (or on the item's container) in a conspicuous place as legibly, indelibly, and permanently as the nature of the item or container will permit. The country of origin is defined as that manufacturing country wherein the item obtained its present identity as a part, sub-assembly or finished product.

In addition to the item markings, all domestic and foreign shipping containers **must** be identified as described below; this includes bagged or boxed items within a container or containers within a unit load shipper.

### 6.1.2 Shipping Packages: Celestica Bar Code Standard for Procured Production Goods.

- Please refer to the document Bar Code Standard for Procured Production Goods. CELQ-033-STD-051.
- The above document is also available electronically and may be found on the Celestica web site:-

Internet access:

[http://www.celestica.com/uploadedFiles/Supply\\_Chain\\_Management/Bar\\_Coding\\_Std\\_for\\_Procured\\_Production\\_Goods\\_CELQ03.pdf](http://www.celestica.com/uploadedFiles/Supply_Chain_Management/Bar_Coding_Std_for_Procured_Production_Goods_CELQ03.pdf)

Or follow the route below;

[www.celestica.com](http://www.celestica.com)

From the web page above, select "What We Do"

On the pull down menu, select "Overview"

At the bottom of the page, select the "For information on fulfillment, packaging and distribution for suppliers" link.

On the "Supplier Resources" page, select the "Bar Coding Standard for Procured Production Goods (CELQ-033-STD-051)" document.

### 6.1.2.1 References

Bar Coding Standard for Procured Production Goods – CELQ-033-STD-051

See also IPC/JEDEC J-STD-033 for handling of moisture/reflow sensitive surface mount devices.

## 7.0 Distribution Shipment Criteria for Defects:

This section outlines the inspection acceptance criteria to be used to determine if a packaged product has an adequate level of quality. It is intended as a guideline for inspectors to help identify and correct damaged or incorrectly packaged or labeled products before receiving into the Celestica Warehouse.

### Inspection Requirements

Cosmetic Inspection shall be performed under the following conditions:-

1. Uniform non-directional lighting shall be used. The lighting shall not be manipulated nor should attempts be made to reflect the light off the surfaces.
2. Illumination shall be between 75 and 150 foot-candles.
3. Parts shall be viewed without the aid of magnification.
4. Caution should be taken not to over-inspect. Once the inspection has been completed and the finish accepted the part shall not be examined further for appearance.

### Crushed / Creased / Dented Containers

#### Accept if:

1. A crease or dent in the container does not affect stacking strength.
2. A crease or fold in the container running parallel to the vertical edges of the container does not affect stacking performance.
3. A container is slightly bulging around the center of a container panel.

4. A crease or dent in the container does not tear the corrugated board.

#### Reject if:

1. The container is damaged in such a manner that product protection is at risk.
2. Any of the four vertical container edges (when oriented in the normal shipping orientation) buckle or fold when downward force is applied to the top of the container.
3. The top of the container is crushed or "pushed in" from any top-loading force.
4. The container contains creases which hamper container performance or product protection, such as:
  - Horizontal creases that cross and buckle vertical container edges.
  - Creases or dents that disfigure the container cube (i.e., caved-in sidewalls)

### Holes / Tears

#### Accept if:

1. Container has small cuts or tears in outer liner that do not go completely through the container wall and exposes 3 or less flutes (or lines).

#### Reject if:

1. Container has forkholes or other major punctures.
2. Container has any holes, cuts or tears that go completely through container wall or flaps.

3. Container liner/paper is torn or peeled back exposing more than 3 flutes (or lines) or leaving loose or “flapping” paper.
4. Container sealing tape is torn or broken affecting container closure or if the container shows exposed fibers apparently resulting from label or tape removal.
5. Container has burst corners or seams

**Scuffs / Marks / Dirt / Dust / other visual imperfections**

**Accept if:**

1. Dirt and dust or other imperfections on the container can be wiped or removed from container exterior to return legibility of logos, labels or verbiage.
2. Container shows scuffs or marks from normal handling, especially on or around bottom edges, as long as they do not impact readability or aesthetics of any logos, labels or printing.

**Stains / Water Marks / Printing Flaws**

**Accept if:**

1. Slight container printing imperfections such as small spots or minor ink bleed are present but do not interfere with readability of logos, labels, or printing.

**Extraneous writing / labels**

**Accept if:**

1. Carrier labels/markings are added to stretch wrap or exterior bags or designated container locations.

**Reject if:**

1. Container contains obvious and extraneous handwritten markings on container exterior.
2. Container contains extraneous labels or stickers inconsistently “slapped” on the container without regard to logos, artwork or container aesthetics.

**Pallets**

**Accept if:**

1. Pallet has cracked slats, knots missing, missing chips, or dents.
2. Pallet is discolored or marked.

**Reject if:**

1. Pallet is missing or is no longer effective and cannot perform its intended function.
2. Pallet is missing one or more slats, or more than one-third of the width of any slat.
3. Pallet is wet.

Refer to other sections of this document for acceptance criteria for printing defects.

2. Moisture on the box will not create problems of discoloration, staining or delamination.
3. Fading of natural kraft paperboard liners is evident; this occurs naturally on untreated corrugated board.
4. Naturally-occurring brown or tan spots are evident in the exterior surface of natural kraft corrugated board, up to ¼” in diameter, and up to 10 spots exceeding 1/16” diameter in any 6” square surface. These spots may be located within printed areas.

**Reject if:**

1. Container has noticeable stains or water marks which detract from or interfere with logos, labels, or printing.
2. Container appears to have been exposed to moisture (water stains) or is received moist or wet to the extent that water stains will be induced or delamination of the container will occur.
3. Printed container graphics are faded and/or logos, labels or printing are unreadable or violated by printing flaws or stains.
4. Pallet has been deformed by twisting or racking or otherwise changed from its original shape.

**Foam**

**Reject if:**

1. Voids over ½” diameter are present.
2. Areas with beads are falling off.

**Bags**

**Reject if:**

1. Tears or holes are present.

**Strapping / Edge Protectors / Stretch Wrap / General**

**Accept if:**

3. Strapping or wrapping materials are abraded.
4. Stretch wrap has minor holes

**Reject if:**

1. Any strapping is missing.
2. If any edge protector(s) is/are missing.
3. If strapping is loose to the point that it is not effective.
4. Any packaging components are missing or assembled incorrectly.
5. Stretch or shrink wrap is unraveled